

## RDA FHVP1.5 CE Positioner

1.5 tonne capacity

Red-D-Arc's RDA FHVP1.5 CE positioners provide 360° rotation of a work piece along with 135° forward tilt to better position weldments for better down-hand or automatic welding. All-fabricated steel frames and bases support rotation and tilt spur-gears driven by worm-gear reducers to provide enhanced safety and durability. Powered table tilt and rotation are controlled via push-button pendants for controlling constant-speed up and down tilt, variable-speed table rotation, and forward/stop/reverse table direction/emergency-stop controls, as well as tilt limit-switches (for both directions). Rotation motors are inverter-controlled variable-frequency AC-type, providing a full range of variable-speed control with excellent speed-regulation. Red-D-Arc welding positioners are engineered to provide maximum safety and dependability; control boxes have IP65-rated enclosures with full UL and CE certification and all of our positioners have been tested and certified by UL to establish safe working loads - a first in the weld automation industry.

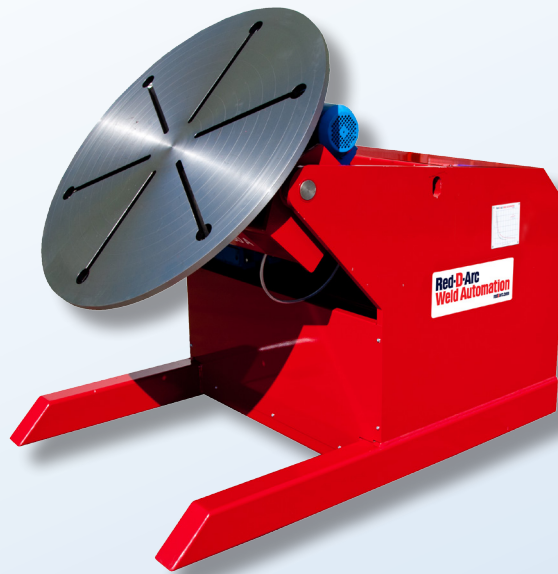

**3**year  
warranty

### Specifications

Model	RDA FHVP1.5 CE
Capacity	1.5 tonne at 150 mm C of G and 150 mm eccentricity
Rotation Speed	0.07 - 1.4 RPM
Rotation Motor	0.75 kW inverter-controlled variable-frequency AC-type
Rotation Torque	2206 Nm
Tilt	135° forward tilt in 30 seconds
Tilt Motor	0.75 kW with brake
Tilt Torque	4413 Nm
Table Height (Horizontal)	975 mm
Table Diameter	920 mm round with six 19 mm slots
Control	Push button pendant, 10 m cable
Control Functions	Tilt up/tilt down/forward/stop/reverse/speed control/emergency stop
Primary Input Power	380 to 480 V, 3 phase, 50/60 Hz
Input Current at Rated Load	4.6 A
Ground Capacity	300 A
Weight	930 kg
Control Box Ingress Protection Rating	IP65
Control Box Electrical Certification	UL508
Loading Capacity Certification	UL2011

Red-D-Arc **Welderentals** rents and sells welding and weld-positioning equipment - around the world.

RDA FHVP1.5 CE Positioner

1.5 tonne capacity

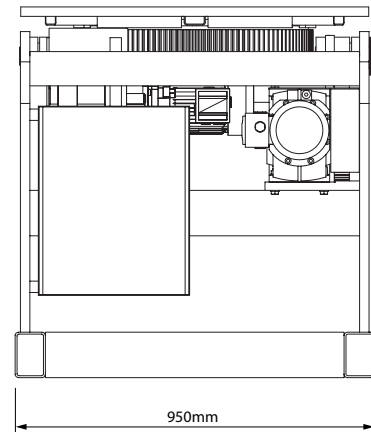
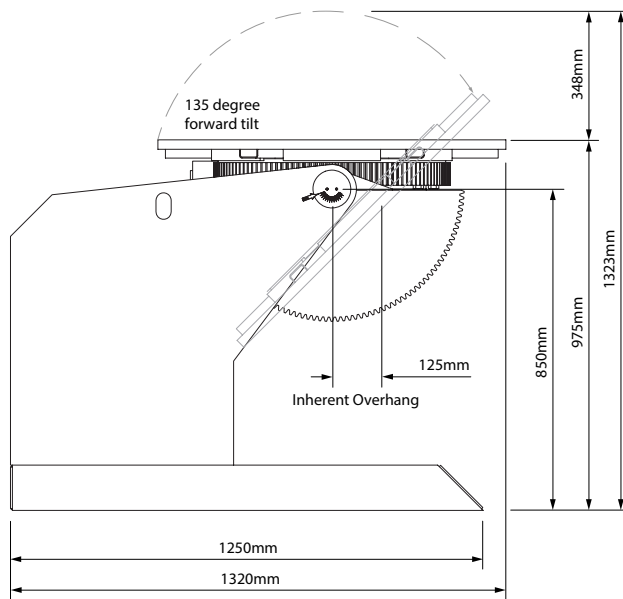
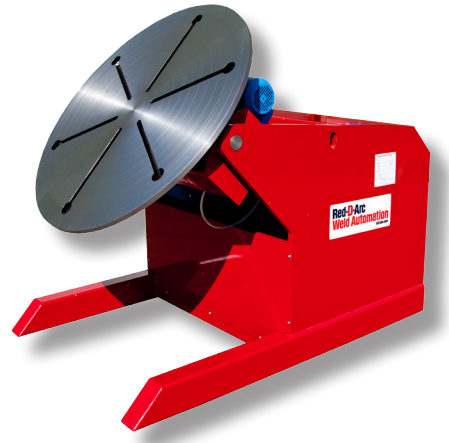
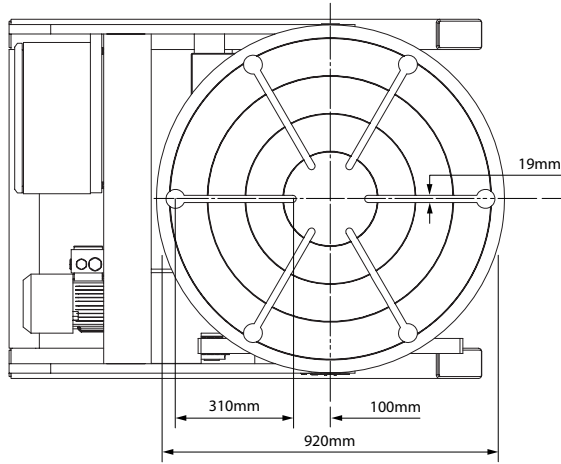

Rotating

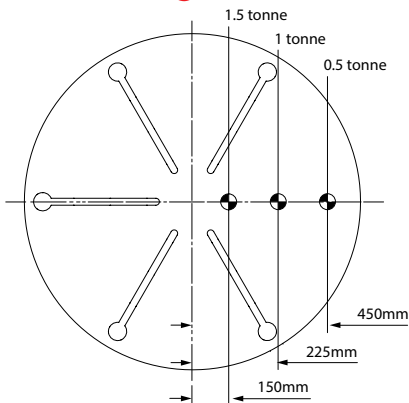

Load (tonne)	Eccentricity (mm)
1.5	150
1.25	180
1	225
0.75	300
0.5	450
0.25	900

Tilting

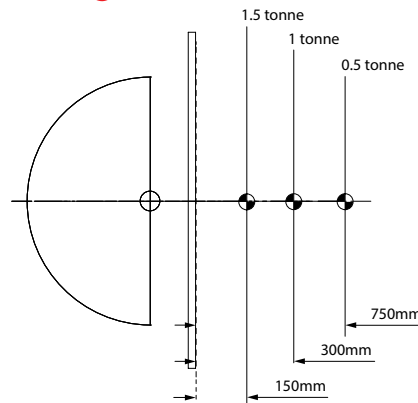

Load (tonne)	C of G (mm)
1.5	150
1.25	210
1	300
0.75	450
0.5	750
0.25	1650

+44 (0) 1744 850085

0800 917 1149