

FastCool

10

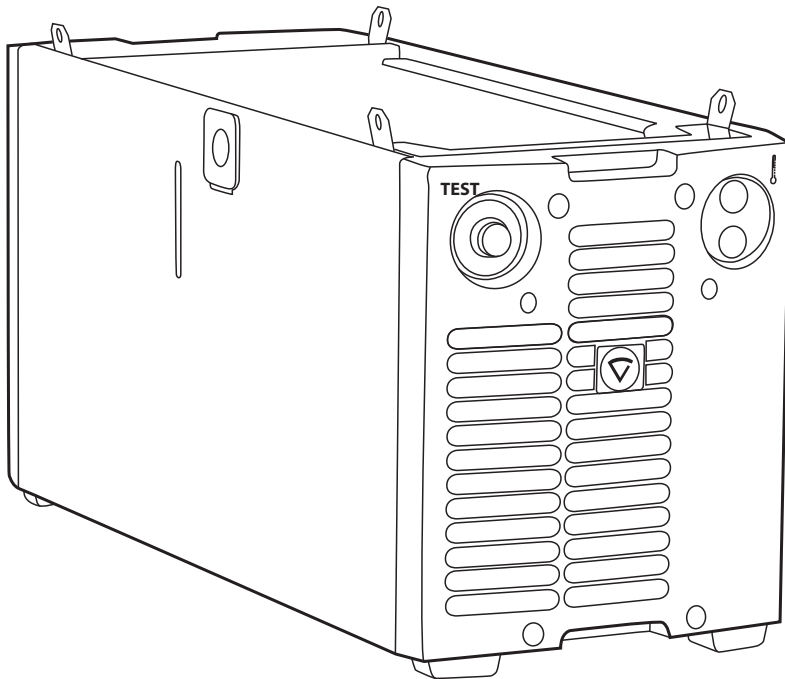

- Operating manual **EN**
- Bruksanvisning **DA**
- Gebrauchsanweisung **DE**
- Manual de instrucciones **ES**
- Käyttöohje **FI**
- Manuel d'utilisation **FR**
- Manuale d'uso **IT**
- Gebruiksaanwijzing **NL**
- Bruksanvisning **NO**
- Instrukcja obsługi **PL**
- Manual de utilização **PT**
- Инструкции по эксплуатации **RU**
- Bruksanvisning **SV**
- 操作手册 **ZH**

OPERATING MANUAL

English

CONTENTS

1.	Preface	3
1.1	General	3
1.2	Product introduction	3
2.	Installation	4
2.1	Removal from packaging	4
2.2	Locating the machine	4
2.3	Serial number	4
2.4	Installation and main parts	4
	2.4.1 Assembling the equipment	4
	2.4.2 Main parts of cooling unit	4
2.5	Preparing for operation	5
3.	Operation	7
3.1	Cooler operation	7
3.2	Overheat signal lamp	7
3.3	Storage	7
4.	Maintenance	8
4.1	Daily maintenance	8
4.2	Every sixth months	8
4.3	Trouble shooting	8
4.4	Disposal of the machine	8
5.	Ordering codes	9
6.	Technical data	9

1. PREFACE

1.1 General

Congratulations on choosing the FastCool 10 cooling unit. Used correctly, Kemppi products can significantly increase the productivity of your welding, and provide years of economical service.

This operating manual contains important information on the use, maintenance and safety of your Kemppi product. The technical specifications of the equipment can be found at the end of the manual.

Please read the manual carefully before using the equipment for the first time. For your own safety and that of your working environment, pay particular attention to the safety instructions in the manual.

For more information on Kemppi products, contact Kemppi Oy, consult an authorised Kemppi dealer, or visit the Kemppi web site at www.kemppi.com.

The specifications presented in this manual are subject to change without prior notice.

Important notes

Items in the manual that require particular attention in order to minimise damage and personal harm are indicated with the **'NOTE!'** notation. Read these sections carefully and follow their instructions.

Disclaimer

While every effort has been made to ensure that the information contained in this guide is accurate and complete, no liability can be accepted for any errors or omissions. Kemppi reserves the right to change the specification of the product described at any time without prior notice. Do not copy, record, reproduce or transmit the contents of this guide without prior permission from Kemppi.

1.2 Product introduction

FastCool 10 is a cooling unit designed for FastMig-welding equipment and to be used for cooling welding gun. The operation of FastCool is controlled by a microprocessor.

2. INSTALLATION

2.1 Removal from packaging

The equipment is packed in durable packages specially designed for them. Check the equipment before taking it into use, to make sure that the equipment or a part of it have not got damaged during the transportation. Also check that the delivery corresponds your order and that you have received all the necessary instructions for installing and operating the equipment. The packaging material can be recycled.

2.2 Locating the machine

Place the machine on a horizontal, stable and clean ground. Protect the machine from heavy rain and burning sunshine. Check that there is enough space for cooling air circulation in front of and behind the machine.

2.3 Serial number

The serial number of the machine is marked on the machine CE-marking. Identifying the serial number is the only proper means of maintaining and identifying parts for a specific product. It is important to make correct reference to the serial number of the product when making repairs or ordering spare parts.

2.4 Installation and main parts

2.4.1 Assembling the equipment

The equipment is assembled in the following order:

1. Transport unit PM500 6185291
2. Cooling unit FastCool 10 6068100

Assembly the transport unit according to the instructions in the package. Fasten the cooling unit to the transport unit by using the screws and bolts delivered with the equipment.

2.4.2 Main parts of cooling unit

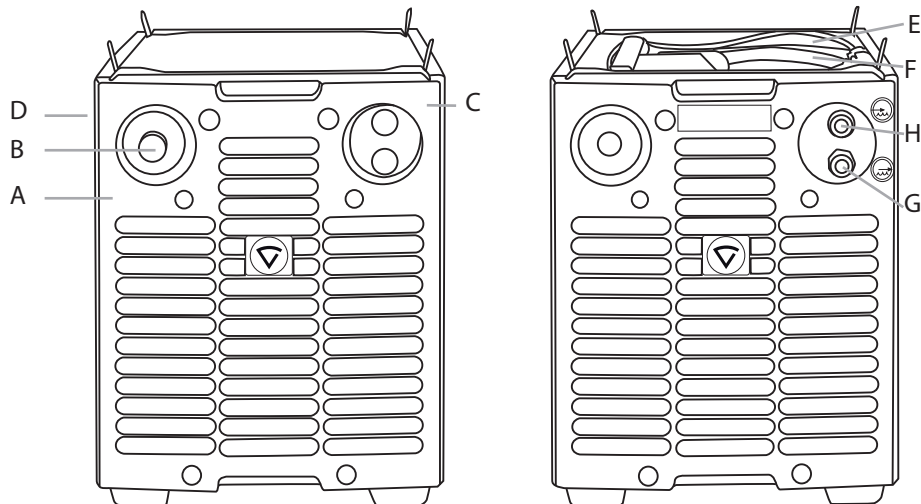

Front machine

- A. Housing
- B. Test switch
- C. Overheat control lamp
- D. Filling hole

Back side

- E. Mains voltage connection cable
- F. Control cable
- G. Cooling water output hose
- H. Cooling water input hose

2.5 Preparing for operation

NOTE! Cooling liquid is injurious! Avoid also contact with skin or eyes. In case of injury, seek for medical advice.

See also 2.4.2. Main parts of cooling unit.

1. Connect the mains voltage and control connectors of the cooler unit to the corresponding connectors on the base of the power supply. The connection can be established through the base of the power supply when the devices are separated or through the right side of the FastCool 10 by removing the right side plate.

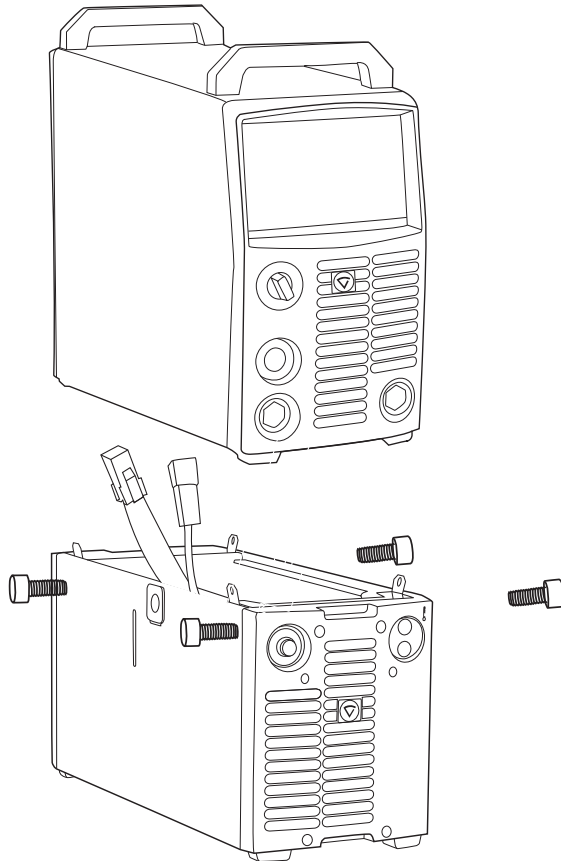

2. Attach the power supply on the FastMig 10 cooler.
3. Connect the cooling water hoses with the wire feed unit, follow colour markings.
4. Fill the reservoir with cooling liquid. It is preferred to use Kemppi brand cooling liquid. Also water can be used, if the temperature doesn't go below 0 degrees Celsius. The capacity of the reservoir is 3 litres.
5. Switch on the power supply.
6. Press and hold down the test switch until the torch hoses are filled with liquid.
7. Depending on the FastMig model in question and the control panel type fitted, please follow the graphical instruction below in order to deselect or select water-cooling function. FastMig Pulse or FastMig X operation is set to 'AUTO', FastMig KM, KMS and M equipment is set as water function 'ON' from the factory. If no cooler is fitted, deselect the cooler function as instructed. Welding will be prevented if cooler function is enabled and no cooler is fitted.

NOTE! When FastCool 10 is connected to the FastMig power source for the first time, the cooler function is normally active. To deselect the cooler function, follow the instructions below depending on the power source type in use.

FastMig KM

When leaving the factory, cooling unit status is set 'ON'. If no cooling unit is connected, set the cooling unit status to 'OFF'. Follow the instructions described in the graphic below for SF 51/SF 54 panels. Having selected the cooling state required, reset the power source by switching off at the main on/off switch. Restart the power source and weld.

FastMig KMS and FastMig M

When leaving the factory, cooling unit status is set 'ON'. If no cooling unit is connected, set the cooling unit status to 'OFF'. Depending on your panel type follow the instructions described in the graphic below. Having selected the cooling state required, reset the power source by switching off at the main on/off switch. Restart the power source and weld.

SF 51/SF 54

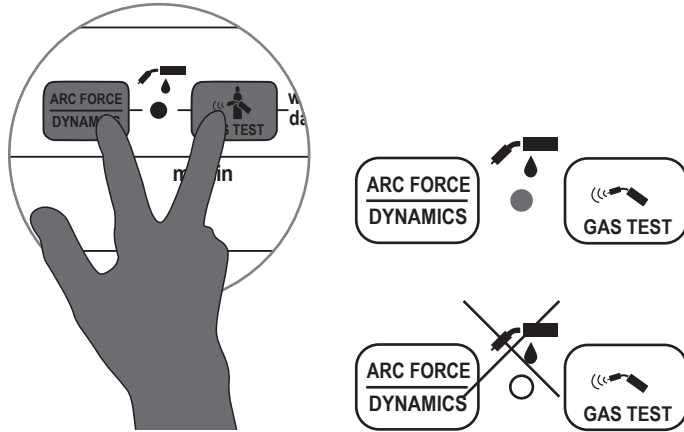

MR 200/MR 300

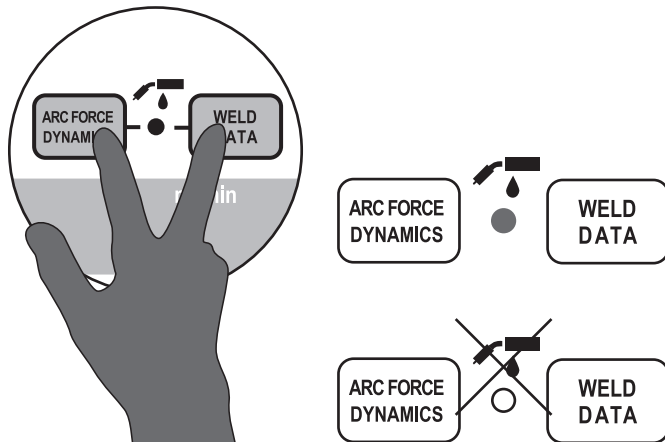

SF 52W/SF 53W and MS 200/MS 300

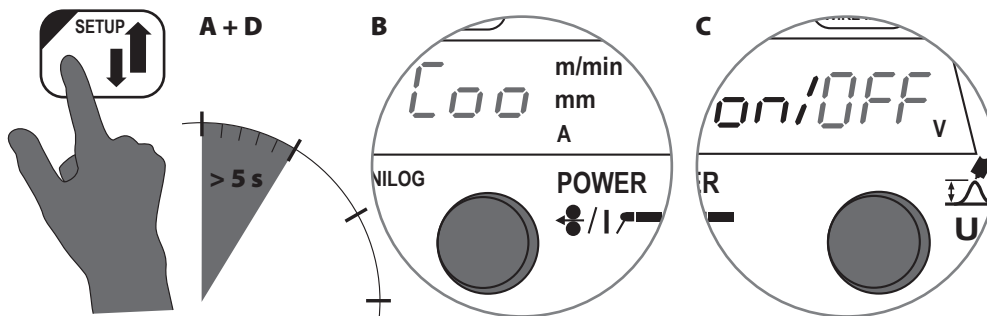

FastMig Pulse and FastMig X

The factory default setting for FastMig Pulse is AUTO. If a cooling unit is not connected and the operator tries to establish gas-cooled operation together with a gas-cooled gun, Err 27 is displayed. To establish gas-cooled operation, select cooler 'OFF'. This is done in the 'System Config Menu' as follows: Press the Menu button on the P 65 or X 37 power source panel. Move the menu display arrow (via panels left-hand up-down arrow keys) to select 'System Config Menu' and then press select button. Choose 'Water Cooling:Auto' and change via control knob to setting 'Water Cooling:OFF', then press Back/Exit. Cooler will then be set to the 'OFF' state for gas-cooled operation. Reset power source via on/off switch and continue welding.

When selected, the operation of the cooling unit is automatic, starting when welding commences. When welding stops the pump will continue operation for approx. 5 min, so reducing the gun and the cooling liquid to ambient temperature.

After completing the preparations explained above, the device is ready for welding. Before welding, read the operating instructions.

3. OPERATION

3.1 Cooler operation

See also 2.4.2. Main parts of cooling unit

FastMig 10 cooler operation is controlled by the microprocessor of the power supply. The cooler pump starts to operate when the welding begins. After the welding has stopped, the pump will operate 1 to 5 minutes longer depending on the welding time. During this time the liquid will cool down to the ambient temperature and cools down the welding gun.

Check the tank liquid level regularly and add liquid, if necessary.

If the tanks coolant liquid level runs low, welding is stopped and an error code appears on the FastMig panel. See trouble-shooting 4.3.

3.2 Overheat signal lamp

The overheat signal lamp is lighting when temperature control of the machine has detected cooling water overheat. The ventilator cools down the machine and when the lamp goes out welding can be started again.

3.3 Storage

The machine must be stored in a clean and dry room. Protect the machine from rain and keep it away from direct sunshine in places where temperature exceeds +25° C. Check that there is free space in front of and behind the machine for air circulation.

4. MAINTENANCE

NOTE! Watch out for mains voltage when handling electric cables!

In planning product maintenance machine utilization degree and circumstances should be considered. Careful use and preventive maintenance help to avoid unnecessary production disturbances and breaks.

4.1 Daily maintenance

The following maintenance operations should be carried out daily:

- Check water level and input flow, add liquid if needed.
- Check cables and connections. Tighten, if necessary and replace defect parts.
- Check that there are no leakages in the cooling water hoses.

4.2 Every sixth months

The following maintenance operations should be carried out at least every sixth months:

- Clean off dust and dirt. Change the cooling liquid and wash up the pipes and water reservoir with pure water.
- Check seals, cables and connections. Tighten, if necessary and replace defect parts.

4.3 Trouble shooting

See also 3.2. Overheat signal lamp.

Overheat signal lamp is lit.

The unit is overheated.

- Check water circulation.
- Check that there is enough free space behind the machine for cooling air circulation.

Error code Err 5/Err 27 on the FastMig panel

- Check the liquid hoses for damages.
- Remove any hose blockages.
- Check water circulation, add liquid if needed.

For further information and assistance, contact your nearest Kemppi service workshop.

4.4 Disposal of the machine



Do not dispose of electrical equipment with normal waste!

In observance of European Directive 2002/96/EC on waste electrical and electronic equipment, and its implementation in accordance with national law, electrical equipment that has reached the end of its life must be collected separately and taken to an appropriate environmentally responsible recycling facility.

The owner of the equipment is obliged to deliver a decommissioned unit to a regional collection centre, per the instructions of local authorities or a Kemppi representative. By applying this European Directive you will improve the environment and human health.

5. ORDERING CODES

Cooling unit FastCool 10		6068100
Welding cooling liquid	In 10 litre cans	SP9810765

6. TECHNICAL DATA

FastCool 10		
Operating voltage		400V -15% ... +20%
Connection capacity	100 % ED	250 W
Cooling power		1 kW
Start pressure, max.		0.4 MPa
Cooling liquid		Kemppi brand cooling liquid
Tank volume		ca. 3 l
External dimensions	LxWxH	570 x 230 x 280 mm
Weight		11 kg
Operating temperature range		-20 ... +40 °C
Storage temperature range		-40 ... +60 °C
EMC class		A
Degree of protection		IP23S

EN

KEMPPI OY

Kempinkatu 1
PL 13
FIN-15801 LAHTI
FINLAND
Tel +358 3 899 11
Telefax +358 3 899 428
export@kemppi.com
www.kemppi.com

Kotimaan myynti:

Tel +358 3 899 11
Telefax +358 3 734 8398
myynti.fi@kemppi.com

KEMPPI SVERIGE AB

Box 717
S-194 27 UPPLANDS VÄSBY
SVERIGE
Tel +46 8 590 783 00
Telefax +46 8 590 823 94
sales.se@kemppi.com

KEMPPI NORGE A/S

Postboks 2151, Postterminalen
N-3103 TØNSBERG
NORGE
Tel +47 33 346000
Telefax +47 33 346010
sales.no@kemppi.com

KEMPPI DANMARK A/S

Literbuen 11
DK-2740 SKOVLUNDE
DANMARK
Tel +45 4494 1677
Telefax +45 4494 1536
sales.dk@kemppi.com

KEMPPI BENELUX B.V.

NL-4801 EA BREDA
NEDERLAND
Tel +31 765717750
Telefax +31 765716345
sales.nl@kemppi.com

KEMPPI (UK) LTD

Martti Kemppi Building
Fraser Road
Priory Business Park
BEDFORD, MK44 3WH
UNITED KINGDOM
Tel +44 (0)845 6444201

Telefax +44 (0)845 6444202
sales.uk@kemppi.com

KEMPPI FRANCE S.A.S.

65 Avenue de la Couronne des Prés
78681 EPONE CEDEX
FRANCE
Tel +33 1 30 90 04 40
Telefax +33 1 30 90 04 45
sales.fr@kemppi.com

KEMPPI GMBH

Perchstetten 10
D-35428 LANGGÖNS
DEUTSCHLAND
Tel +49 6 403 7792 0
Telefax +49 6 403 779 79 74
sales.de@kemppi.com

KEMPPI SPÓŁKA Z O.O.

Ul. Borzymowska 32
03-565 WARSZAWA
POLAND
Tel +48 22 7816162
Telefax +48 22 7816505
info.pl@kemppi.com

KEMPPI AUSTRALIA PTY LTD

13 Cullen Place
P.O. Box 5256, Greystanes NSW 2145
SMITHFIELD NSW 2164
AUSTRALIA
Tel. +61 2 9605 9500
Telefax +61 2 9605 5999
info.au@kemppi.com

ООО КЕМППИ

Polkovaya str. 1, Building 6
127018 MOSCOW
RUSSIA
Tel +7 495 240 84 03
Telefax +7 495 240 84 07
info.ru@kemppi.com

ООО КЕМППИ

ул. Полковоя 1, строение 6
127018 Москва
Tel +7 495 240 84 03
Telefax +7 495 240 84 07
info.ru@kemppi.com

KEMPPI WELDING TECHNOLOGY (BEIJING) CO., LTD.

Unit 105, 1/F, Building #1,
No. 26 Xihuan South Rd.,
Beijing Economic-Technological Development
Area (BDA),
100176 BEIJING
CHINA
Tel +86-10-6787 6064
+86-10-6787 1282
Telefax +86-10-6787 5259
sales.cn@kemppi.com

肯倍焊接技术 (北京) 有限公司

中国北京经济技术开发区
西环南路26号
1号楼1层105室(100176)
电话 : +86-10-6787 6064/1282
传真 : +86-10-6787 5259
sales.cn@kemppi.com

KEMPPI INDIA PVT LTD

LAKSHMI TOWERS
New No. 2/770,
First Main Road,
Kazura Garden,
Neelankarai,
CHENNAI - 600 041
TAMIL NADU
Tel +91-44-4567 1200
Telefax +91-44-4567 1234
sales.india@kemppi.com

KEMPPI WELDING SOLUTIONS SDN BHD

No 12A, Jalan TP5A,
Taman Perindustrian UEP,
47600 Subang Jaya,
SELANGOR, MALAYSIA
Tel +60 3 80207035
Telefax +60 3 80207835
sales.malaysia@kemppi.com

Declaration of Conformity

We Kemppe Oy at address below declare under our sole responsibility that the product detailed below, to which this declaration relates, complies with the protection requirements of the EC electromagnetic compatibility Directive 2014/30/EU, the essential health and safety requirements of the low voltage Directive 2014/35/EU and Directive 2011/65/EU on the restriction of the use of certain hazardous substances in electrical and electronic equipment.

Product name	Product n:o
Cool X	6068200
FastCool 10	6068100

Product description: Arc welding equipment

The above mentioned product(s) are in conformity with the following EN- and IEC-standards.

EN 60974-2:2013
IEC 60974-2:2013

Arc welding equipment
– Part 2: Liquid cooling systems

EN 60974-10:2014 + A1
IEC 60974-10:2014 + A1

Arc welding equipment
– Part 10: Electromagnetic compatibility (EMC) requirements
• Equipment fulfills class A limits

Lahti 16.8.2018



Ville Vuori
Chief Executive Officer