

Specification Data
Column & Boom Manipulator
VHD Series
Range up to 10 metres



TRAVELLING BASE

The **A&N** VHD series of Column & Boom Manipulators are specifically designed and built to withstand the harsh and rugged environments expected in the welding industry. It includes the following features:

- A slewing ring for column mounting, thereby providing a smooth 360-degree lockable rotation.
- All vertical and horizontal rails are precisely machined in single runs giving unsurpassed smooth and steady travel.
- Latest Inverter drives fitted for variable speed of horizontal boom arm travel and rail travel car (optional).
- Worm gearbox for vertical travel via AC motor complete with brake for added safety.
- High tensile roller chain used for vertical travel with the addition of a counter balance system provides smooth effortless vertical travel.
- IP 55 control box and low voltage pendant control station.
- Standard safety feature includes anti-fall device and limit switches for all functions.
- Internally trunked cabling.

Inclusive:

- Power source mounting bracket of your choice

Optional features includes

- Travel car, manual or motorized variable speed operated via the same pendant station via selector switch.
- X-Y slide, manual or motorized, operated via the same pendant station.
- Compressed air operated flux recovery unit
- Welding power source & wire feeder controller system

All **A&N** Column & Boom Manipulators are grit blasted to SA2.5 and two coats of zinc phosphate paint followed by one coat of polyurethane paintwork will ensure that your investment provides you with many years of uninterrupted service.

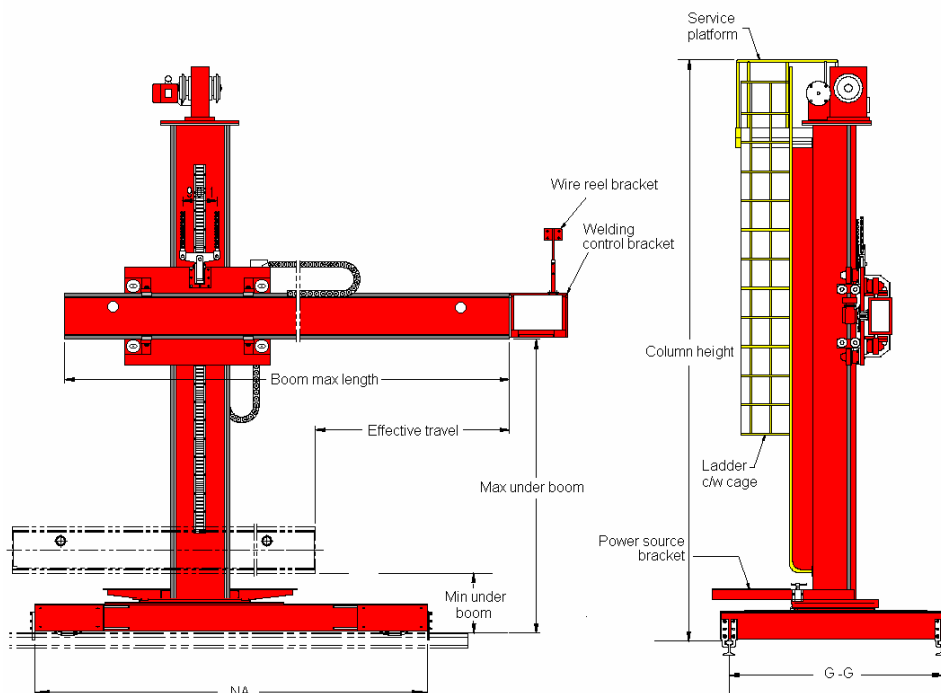

VHD Series Column & Boom (Up to 10m)

VHD series with Travelling Base

DIMENSION SPECIFICATIONS

Model with Travelcar	4040-TCM	4545-TCM	5050-TCM	5555-TCM	6060-TCM	6565-TCM
Column height	5684	6184	6684	7184	7684	8184
Boom length	6500	7000	7500	8000	8500	9000
Vertical under boom (max)	4000	4500	5000	5500	6000	6500
Boom effective range	4000	4500	5000	5500	6000	6500

Model with Travelcar	7070-TCM	7575-TCM	8080-TCM	8585-TCM	9090-TCM	9595-TCM	100100-TCM
Column height	8684	9184	9684	10184	10684	11184	101684
Boom length	9500	10000	10500	11000	11500	12000	102500
Vertical under boom (max)	7000	7500	8000	8500	9000	9500	10000
Boom effective range	7000	7500	8000	8500	9000	9500	10000

DATA SPECIFICATIONS

Vertical Speed	1250mm/min
Boom Speed	150~1500mm/min
Travel Speed	200~2500mm/min
Vertical Drive	AC 2.2kw c/w brake
Boom Drive	AC 0.75kw c/w force cooling
Travel car Drive	AC 0.75kw c/w brake
Electrical Panel	IP55 class
Base Type	Motorized Travel car
Travel car G-G Rail	Factory advice
Slewing	Manual
Power Supply	3-phase line
Control Voltage	24Vac
Control Means	Push button pendant c/w M cable
Surface Preparation	Gritblast to SA2.5
Painting	2 coats zinc phosphate 1 coat polyurethane
Color	RAL5015 blue

Note: Scope of cutting table, rail base support and civil works (By Others)

OPTIONS

X-Y Slides 200mm slide	■
Slewing Drive	■
Welding Control	■
Welding Power Source	■
Flux Recovery	■
Walk way	■
Cat Ladder	■

▲ Specify requirement ■ Optional □ Standard □ Specify quantity

Table 4: VHD Type Travelcar Rails G-G in mm (300kg Payload)

V \ H	25	30	35	40	45	50	55	60	65	70	75	80	
40	1650				2000			2500				3000 CW	
45													
50													
55													
60					2000			2500		3000			
65													
70													
75													
80													

Notes:

V denotes Max.Under Boom Height (Vertical), in hundreds of mm. i.e. 20 = 2000mm

H denotes Effective Boom Travel (Horizontal), in hundreds of mm. i.e. 20 = 2000mm

CW denotes with Counterweight

VHD series with Fixed Base

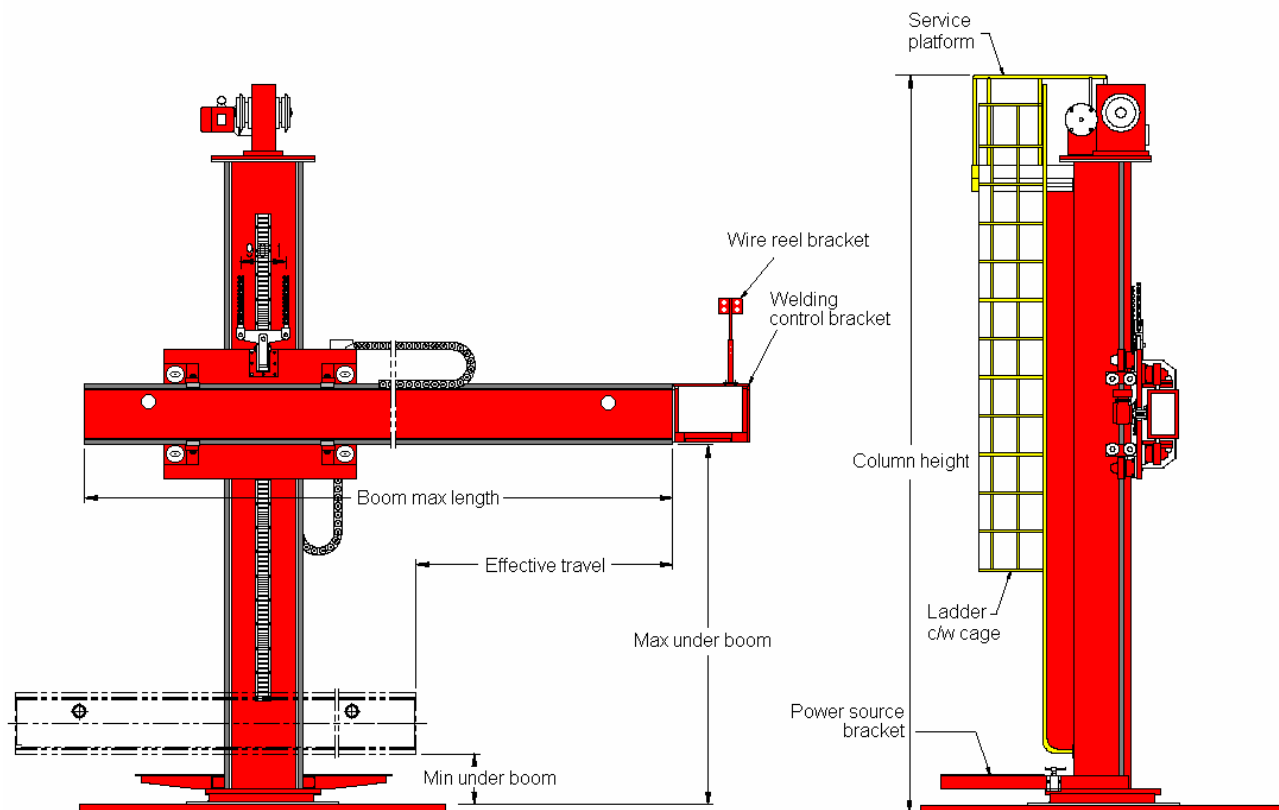

DIMENSION SPECIFICATIONS

Model	4040	4545	5050	5555	6060	6565
Column height	5684	6184	6684	7184	7684	8184
Boom length	6500	7000	7500	8000	8500	9000
Vertical under boom (max)	4000	4500	5000	5500	6000	6500
Boom effective range	4000	4500	5000	5500	6000	6500

Model with TCM	7070	7575	8080	8585	9090	9595	100100
Column height	8684	9184	9684	10184	10684	11184	101684
Boom length	9500	10000	10500	11000	11500	12000	102500
Vertical under boom (max)	7000	7500	8000	8500	9000	9500	10000
Boom effective range	7000	7500	8000	8500	9000	9500	10000

DATA SPECIFICATIONS

Vertical Speed	1250mm/min
Boom Speed	150~1500mm/min
Travel Speed	200~2500mm/min
Vertical Drive	AC 2.2kw c/w brake
Boom Drive	AC 0.75kw c/w force cooling
Electrical Panel	IP55 class
Base Type	Motorized Travel car
Slewing	Manual
Power Supply	3-phase line
Control Voltage	24Vac
Control Means	Push button pendant c/w M cable
Surface Preparation	Gritblast to SA2.5
Painting	2 coats zinc phosphate 1 coat polyurethane
Color	RAL5015 blue

Note: Scope of cutting table, rail base support and civil works (By Others)

OPTIONS

X-Y Slides 200mm slide	<input type="checkbox"/>
Slewing Drive	<input type="checkbox"/>
Welding Control	<input type="checkbox"/>
Welding Power Source	<input type="checkbox"/>
Flux Recovery	<input type="checkbox"/>
Walk way	<input type="checkbox"/>
Cat Ladder	<input type="checkbox"/>

▲ Specify requirement Optional Standard Specify quantity

Specification for Manipulator

1	Model	RM4545VHD-FB-XA
2	Vertical Speed	1060 mm/min at 50Hz, 2.2KW c/w Brake
3	Boom Speed	165~1650mm/min at 5~50Hz, AC 0.55KW c/w Force Cooling
4	Travel Speed	N.A.
5	Welding Control/ Brand	T.B.A.
6	Welding Power Source/ Brand	T.B.A.
7	Operator Chair	No
8	Controller bracket	Yes
9	X-Y Slide	No.
10	Wire-reel bracket	Yes
11	Flux Recovery	No.
12	Electrical Panel	Yes
13	Base Type	Fixed Base
14	Power Source Bracket	Yes
15	Slewing Feature	Yes. Manual
16	Power Supply	400V-3P-50Hz
17	Travelcar Track Gauge	N.A.
18	Control Voltage	24Vac
19	Control Means	Via Pendant Control c/w 14m cable
20	Surface Preparation	Gritblast to SA2.5
21	Painting	2 coats Zinc Phosphate, 1 coat Polyurethane
22	Color	RAL 3003 Red
23	Qty	T.B.A

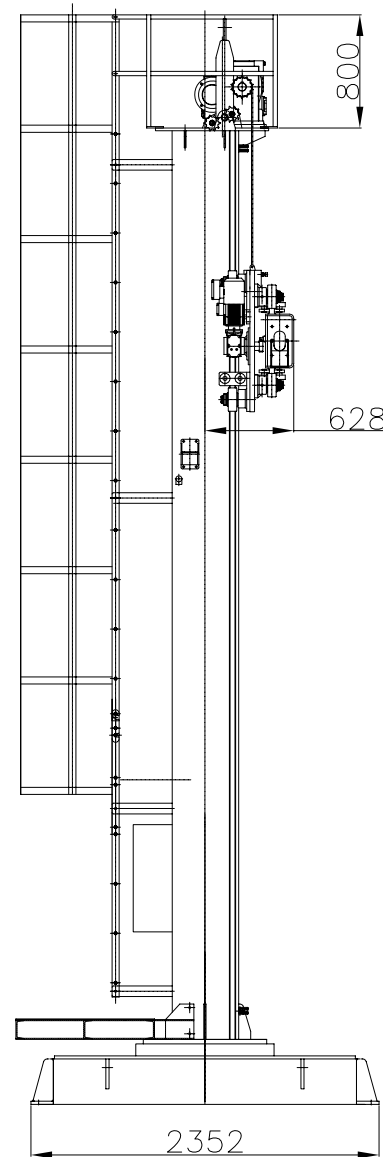
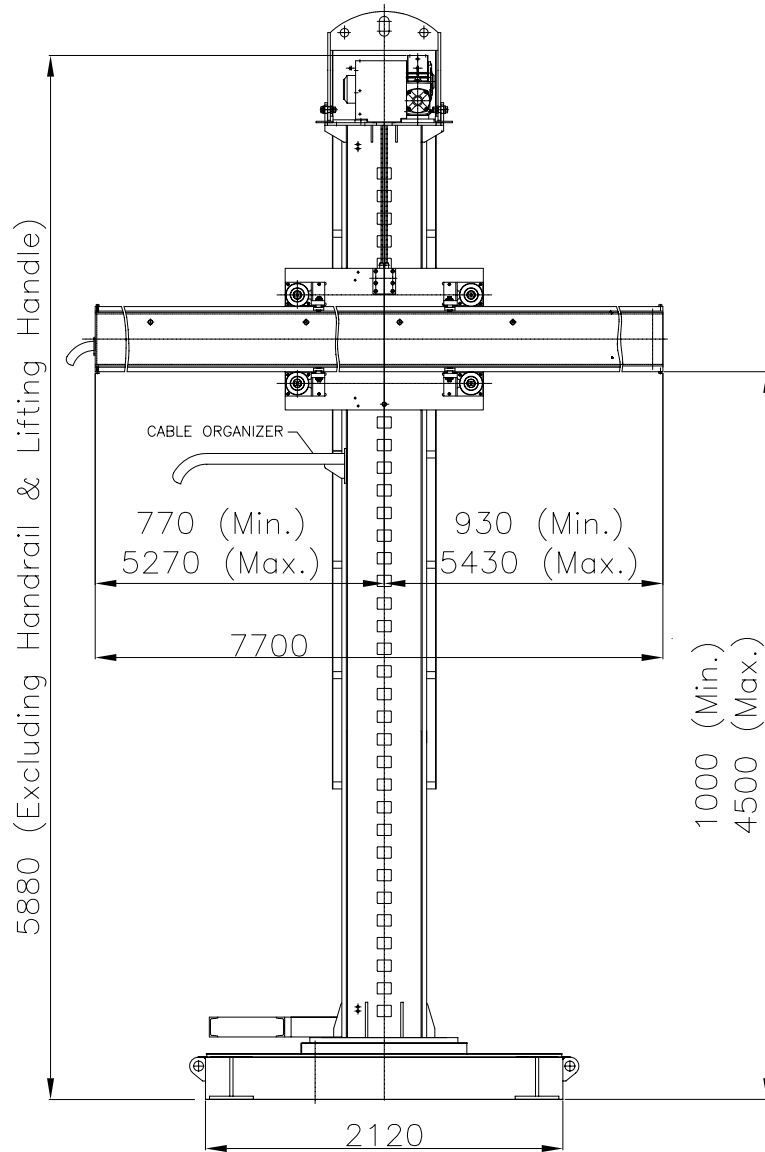

ALL DIMENSIONS IN MM, UNLESS OTHERWISE SPECIFIED.

 A&N PLANT <small>ROTATORS - COLUMN BOOMS - POSITIONERS</small>		PROJECT TITLE : RM4545VHD-FB-XA	
DRAWN Mic		CLIENT : -	
APPROVED		DWG. NAME : MANIPULATOR GENERAL ASSEMBLY	
		DWG. NO : AN-RM4545VHD-FB-XA	
		SCALE: N.T.S.	
		REVISION: 0	
		SHEET NO: 1 OF 1	
THE ORIGINAL AND ALL COPIES OF THIS DRAWING TOGETHER WITH THE COPYRIGHT THEREOF ARE THE SOLE PROPERTY OF R.P.E. PTE. LTD. SINGAPORE			

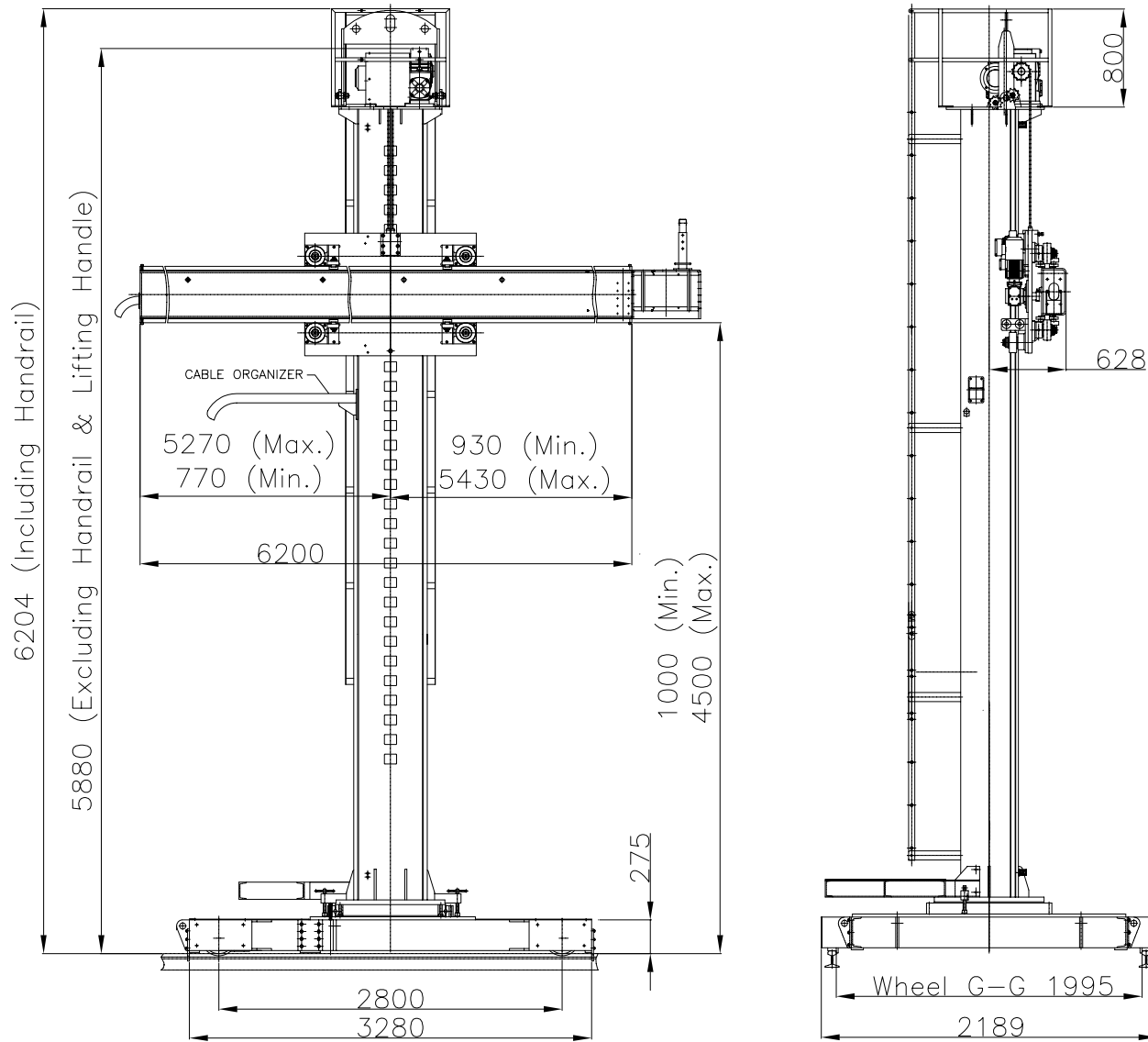

Specification for Manipulator

1	Model	RM4545VHD-TCM-XA-G2000
2	Vertical Speed	1270 mm/min at 50Hz, 3KW c/w Brake
3	Vertical Brake Supply	400V-3P-50Hz
4	Boom Speed	165~1650mm/min at 5~50Hz, AC 0.55KW c/w forced cooling
5	Forced Cooling Fan Supply	230V-1P-50Hz
6	Travel Speed	285~2850mm/min at 5~50Hz, AC 0.75KW c/w Brake
7	Travel Brake Supply	230V-1P-50Hz
8	Welding Control/ Brand	Miller HDC 1500 (By Client)
9	Welding Power Source/ Brand	Miller Dimension 1250 (By Client)
10	Operator Chair	No
11	Controller bracket	Yes, For Miller
12	X-Y Slide	No.
13	Wire-reel bracket	Yes, For Miller
14	Flux Recovery	No.
15	Electrical Panel	No.
16	Base Type	Motorized Travelcar
17	Power Source Bracket	Yes, For Miller
18	Slewing Feature	Yes. Manual
19	Power Supply	400V-3P-50Hz
20	Travelcar Track Gauge	Rail G-G 2000mm for Wheel G-G 1995mm
21	Control Voltage	N.A.
22	Control Means	N.A.
23	Surface Preparation	Gritblast to SA2.5
24	Painting	2 coats Zinc Phosphate, 1 coat Polyurethane
25	Color	RAL 3003 Red
26	Qty	2 units

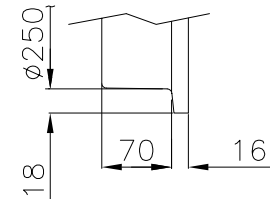

Wheel Profiles (For Reference)

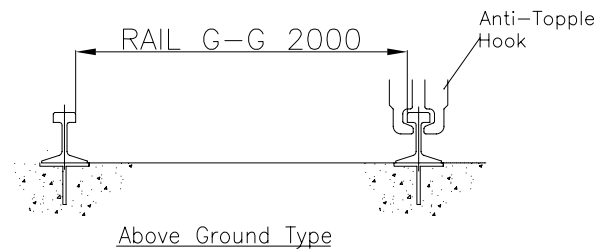

ALL DIMENSIONS IN MM, UNLESS OTHERWISE SPECIFIED.

A&N PLANT <small>ROTATORS - COLUMN BEAMS - POSITIONERS</small>		PROJECT TITLE : RM4545VHD-TCM-XA-G2000	
DRAWN : Kris		CLIENT : A&N Plant	
APPROVED :		DWG. NAME : MANIPULATOR GENERAL ASSEMBLY	
		DWG. NO : PJ-3884-GA01	
		SCALE: N.T.S.	
		REVISION: 0	
		SHEET NO: 1 OF 1	

THE ORIGINAL AND ALL COPIES OF THIS DRAWING TOGETHER WITH THE COPYRIGHT THEREOF ARE THE SOLE PROPERTY OF R.P.E. PTE. LTD. SINGAPORE